

Instruction Manual

AT210 Wireless Digital Thermometer

Version 1.1 (August, 2015)

1. Features

The AT210 wireless digital thermometer can be used for remote temperature monitoring. It consists of two units: AT210-A (slave unit) and AT210-B (master unit). The slave unit connects to the temperature sensor and displays measured value. It also sends the measured temperature reading to the master unit and allow remote monitoring and remote parameter setting through wireless connections. The master unit can communicate with up to 10 slave units. The AT210 thermometer have two alarm settings for a built-in buzzer. One can be used for high limit alarm and the other can be used for low fuel (limit) alarm. This thermometer can also store the highest temperature reading with a time stamp during the temperature monitoring process. The slave unit has a 12VDC 2.5mm power output that is synchronized with the build-in alarm buzzer, which can be used to drive an external buzzer or other devices. Both units are powered by 12VDC through an 2.1mm AC adapter for continuous operation. It can also be powered by a car battery directly.

2. Specifications

- ◆ Power input: 12VDC (2.1mm OD connector)
- ◆ AC adaptor: 100-240V, 50/60Hz input. 12 VDC, 1 Amp output.
- ◆ Power consumption: <0.5W
- ◆ Sampling rate: 2 samples/second
- ◆ Accuracy: 0.2% full scale
- ◆ Thermometer reading range: -320-2300°F (-200~1300°C).
- ◆ Power output (on slave unit): 12VDC (2.5mm OD connector), 1 Amp, synchronized with the internal buzzer.
- ◆ LED display: 0.39", red
- ◆ Internal buzzer: two alarms (high limit or low limit alarm).
- ◆ Dimension: 2.8x3.5x1.2" (70x90x30mm)

3. Front panel

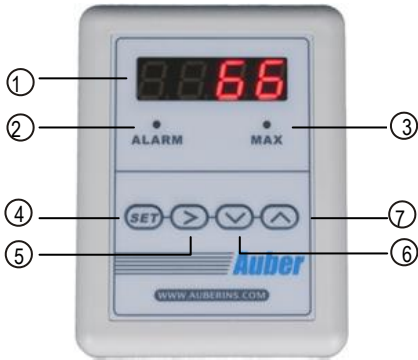

Figure 1. Front panel of AT210-A and B.

1. Digital display window.
2. Alarm indicator: blinking when alarm is triggered.
3. Peak value indicator: stay solid on when peak value is displayed, blinking when the time stamp of the peak value is displayed.
4. Set key: enter code; confirm input value.
5. Shift key: shift digit; mute the alarm buzzer.
6. Down key: change digit value; move to the previous parameter; display peak temperature and the time when peak temperature is reached/ reset peak values.
7. Up key: change digit value / move to next parameter / change brightness.

4. Connectors on the meter

The connectors on the meter are shown in Figure 2. Connecting the 12V DC power adapter to the connector 1 from wall outlet. Connecting the external buzzer to connector 2. The polarity for this socket is center pin positive (+), outer collar negative (-). Connect the K thermocouple to terminal 3. Please note that thermocouple connector also has polarity. The wide blade should go to the wide slot.



① Power Input - 12VDC power supply input (2.1 mm O.D.). ② Power Output - 12VDC output (2.5 mm O.D.). ③ Probe Input - temperature probe input

Figure 2. Bottom view of AT210-A (left, slave unit) and AT210-B (right, master unit).

5. Basic functions for temperature monitoring

During the normal temperature monitoring mode, you can mute the alarm, check the peak value, and change display brightness with the keys on the front panel (Figure 3).

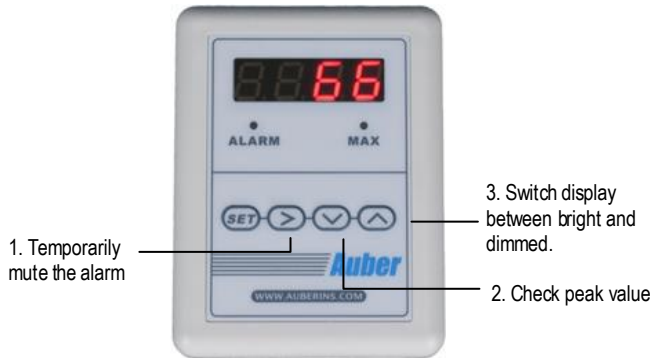

Figure 3. Operating keys on AT210-A and B.

Function Descriptions:

1. **Temporarily mute the alarm.** When the temperature reaches the alarm temperature, the alarm indicator will flash and meter will start beeping. Press Shift key once can temporarily mute the alarm. Alarm will be triggered again if the alarm set temperature is reached again. Please see Section 6 for detailed explanation alarm settings.
2. **Check the peak value.** Press Down key once to show peak temperature, and the MAX LED will light up; press Down key again to show the time stamp i.e., the time when peak temperature is reached (count from the start of the timer, unit is seconds), and the MAX LED will flash. If the temperature continues rising, a new peak temperature and its time will be written to the memory to replace the previous peak value. Please see Section 9 for details.
3. **Dimmer the display brightness.** Press Up key to toggle the display brightness between the dimmed display and the normal bright display. The brightness of the dimmed display is determined by the parameter "brit" described in the later section of the manual (see Section 7).

6. Alarm setting (code 0001)

The meter has two programmable alarms that can be set to turn on the buzzer at specified temperatures. The alarm1 is controlled by parameters AH1 and AL1; the alarm2 is controlled by AH2 and AL2. These parameters can be accessed by code 0001 (see Table 1).

Table 1. Alarm parameters.

Symbol	Name	Description	Setting Range	Initial	Note
HH1	AH1	Alarm1 on temperature	-1999 ~ 9999	480	
LL1	AL1	Alarm1 off temperature	-1999 ~ 9999	479	
HH2	AH2	Alarm2 on temperature	-1999 ~ 9999	250	
LL2	AL2	Alarm2 off temperature	-1999 ~ 9999	250	
End	END	Exit			

AH1 and AH2 are called alarm on temperature, i.e. the temperatures at which the Alarm1 and Alarm2 will turn on; AL1 and AL2 are called alarm off temperature, i.e. the temperatures at which the Alarm1 and Alarm2 will turn off. When AH1>AL1(or AH2>AL2), the alarms is set as a high limit alarm. When AH1<AL1(or AH2<AL2), the alarm is set as a low limit alarm. For a high limit alarm, the alarm buzzer should be on once the temperature rise above AH, and it should be off only when the temperature drops below AL. In contrast, for a low limit alarm, the alarm buzzer should be on when the temperature drops below AH, and it should be off only when the temperature rise above AL.

For example, when the temperature unit is set to F (Fahrenheit), AH1=900, and AL1=800, the buzzer will go off once the measured temperature is higher than 900°F; the buzzer will stop when the temperature drops below 800°F. In another case, when AH2=180, AL2=185, the alarm2 is set as a low limit alarm. If the temperature drops below 180°F, the buzzer will go off (on); when the temperature rises above 185°F, the buzzer will stop.

Users can press the Shift key (“>”) to mute the buzzer. The alarm will buzz again if the alarm temperature moves out of the alarm zone (between AH and AL) and re-enters it again. For instance, AH1=900, AL1=800, current temperature is higher than 900, and the alarm is muted. In this case, the temperature has to drop below 800 and rise above 900 again to trigger the alarm buzzer. To disable the alarms, set AH and AL to the same value, i.e., AH1=AL1 and AH2=AL2.

Steps to set an alarm are described below as well as in the flow chart in Figure 4:

- (1) Press SET key, change the code to 0001, and press SET again to enter alarm setting mode.
- (2) Press Up and Down key to select a parameter (AH1, AL1, AH2, or AL2).
- (3) Press SET to view the value of the parameter.
- (4) Use Shift, Up, and Down key to change the value.
- (5) Press SET key to confirm the value and exit from this parameter.
- (6) Press Up or Down key to select the new parameter.
- (7) To exit this mode, press SET key when “End” is displayed.

The procedure is showed in the flow chart in Figure 4.

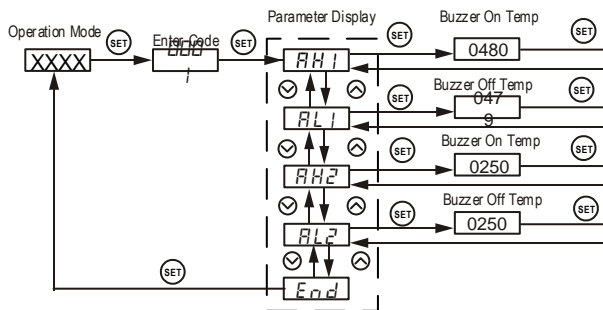

Figure 4. Steps of setting alarms. In this example, alarm1 is set as a high limit alarm at 480; alarm2 is disabled.

7. System settings (code 0089)

The parameters for system configuration is listed in Table 1.

Table 1. System configuration parameters.

Symbol	Name	Description	Setting Range	Initial	Note
<i>IntY</i>	Inty	Input sensor type	K	k	1
<i>PSb</i>	PSb	Input offset	-1000 ~ 8000	0	2
<i>FILt</i>	FILT	Digital filter	0 ~ 3	0	3
<i>C-F</i>	C-F	Temperature unit	°C, °F	°F	4
<i>brIt</i>	Brit	Brightness level of dimmed LED	1-4	1	5
<i>End</i>	END	Exit			6

Note 1. Inty (Input sensor type). This parameter defines the sensor type that is used for the thermometer. If you purchased the thermometer bundle, it is already set for the probe included in the package. You don't need to change it.

Note 2. PSb (input offset). This is to set an offset value to compensate the error produced by the sensor. For example, if the meter displays 5 °C when probe is in ice/water mixture, setting PSb=-5 will make the meter display 0 °C. You can use shift key (second key from the left) to shift to the first left digit, then press down key once to enter minus sign.

Note 3. FILt (digital Filter). If the temperature reading fluctuates due to input noise, a digital filter can be used to smooth the input signal. "FILt" may be configured in the range of 0-3. Higher the value, stronger the filtering effect. A strong filter increases the stability of the readout, but causes longer delay in responding to the temperature change. Set FILt=0 will disable the filter.

Note 4. C-F (temperature unit). Set to C if you want to display temperature in Celsius. Set to F for Fahrenheit.

Note 5. Brit (display dimmer). This parameter sets the brightness level of the dimmed LED display. You can switch the LED brightness level between the dimmed and the normal using UP key. However, the normal brightness level of the LED display is equal to level 4. So if Brit is set to 4, you won't see and change in the brightness of LED display when pressing UP key.

Note 6. End. Exit the parameter setting mode.

Steps to set system parameters are described below as well as in the flow chart in Figure 5:

- (1) Press SET key, change code to 0089, and press SET again to enter the system configuration mode.
- (2) Press Up or Down key to select the parameter to be changed.
- (3) Press SET to view the value of the parameter.
- (4) Press Shift, Up, and Down key to enter a new value.
- (5) Press SET to confirm.
- (6) Press Up or Down to select the new parameter.
- (7) To exit the menu, press SET when "End" is displayed.

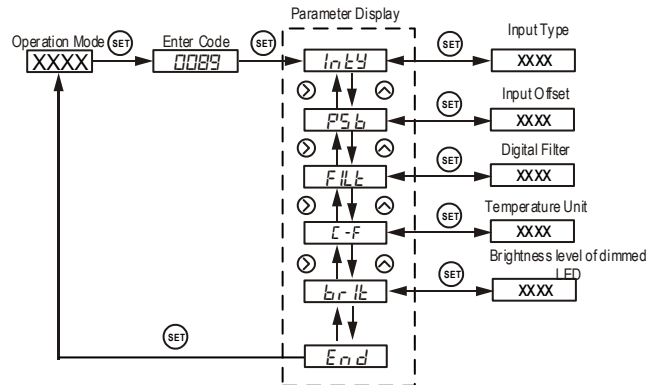

Figure 5. Flow chart of how to set system configuration parameters.

8. Wireless connection setting (code 0110)

The parameters for wireless connection can be accessed by code 0110. The parameters are listed in Table 2.

Table 2. Wireless connection parameters.

Symbol	Name	Description	Setting Range	Initial	Note
<i>bAud</i>	bAud	Baud rate	1200, 2400, 3600, 9600	9600	7
<i>Id</i>	Id	Unit ID	0 ~ 240	1	8
<i>tDLY</i>	tdly *	Hand shake time	2 ~ 60	3.0	9 *
<i>tACy</i>	tACy *	Sampling rate	0.5 ~ 60 per second	1.0	10 *
<i>End</i>	End	Exit			

Note 7. Baud (Baud rate for communication). This should be left as default.

Note 8. Id (Unit ID). Each slave unit should be assigned with a unique Unit ID. The default value is 1. The value of the Unit ID can range from 0 to 240. A master unit can communicate with up to 10 slave units. For example, if you have two slave units, you can set their Unit ID to 1 and 2 respectively. Then, when the master Unit ID is set to 1, it will read the temperature of slave unit 1. When the master Unit ID is set to 2, it will read from slave unit 2. Set two slave units to the same ID number will cause crashes.

Note 9. tdly (Hand shake time). This is the time interval (unit in seconds) after which the master unit will attempt to read signal from the slave unit again. If the master unit receives signal during this hand shake time, it will refresh and display the current reading at the assigned cycle rate. Otherwise, it will display the previous reading for the rest of the current hand shake cycle. If there is still no signal received during the entire hand shake time, the master unit will display four dashes ("----"). This setting can prevent the master unit from frequently switching between temperature reading and four dashes. If the master unit and the slave unit is far away from each other or the signal is weak, user should increase the hand shake time. Placing the master and slave unit too close to each other may also result in no reading on the master unit.

Note 10. tACy (Sampling rate). This parameter sets how frequently the slave unit refresh its reading. The default sampling rate is 1 per second. The unit is s⁻¹ or Hz.

Note *. These two parameters are only available on the master unit.

9. Peak value setting (code 0037)

The peak value (the highest measured temperature) and the peak time (the time at which the peak values is read) can be stored. These parameters for peak values can be accessed by code 0037. The parameters are listed in Table 3 below.

Table 3. Alarm setting parameters.

Symbol	Name	Description	Setting Range	Initial	Note
$\bar{n} R$	mA	Peak value	On/off	On	11
$\bar{n} R t$	mAt	Peak value time	On/off	On	12
$E n d$	End	Exit			

Note 11. mA (Peak Value). The highest temperature reading. By default this function is turned on. The Peak Value will be kept in the memory unless cleared. After the unit is powered on, the previously recorded Peak Value and its time stamp will remain in the memory unless: 1) a new peak value overwrites the previous peak value, 2) or the memory has been reset. Hold the Down key for 2 seconds will reset both the peak value and its time stamp to 0. The recorded peak value can be checked by pressing DOWN key during the normal operating mode; press DOWN key again to display the Peak Value Time; press and hold Down key for 2 seconds to clear the stored Peak Value and the Peak Value Time.

Note 12. mAt (Peak Value Time). The time stamp of the Peak Value. By default this function is turned on. The time is tracked by the build-in timer which is activated whenever the mA function is being turned on. The current Peak Value Time will be overwritten by the new Peak value time. The Peak value time can be checked by pressing DOWN key again in the peak value mode. Pressing the DOWN key 2 seconds will clear the Peak value as well as the Peak value time. Every time the unit is restarted or the Peak Value is cleared, the timer will start over again (unit in seconds).

12. Communication Between the Master Unit and Slave Units.

When the communication between a master unit and a slave unit is established, all the settings and operations on these two units are "mirrored", except for the Unit ID and the operation which temporarily mute the alarm (for the safety reason). You can set all of these parameters from either the slave or the master unit

- 1) Mirrored operations and parameters. Operations and readings on one unit will be mirrored to the other unit. Change of the alarm setting on the master unit will also be synchronized to the slave unit, or vice versa. The temperature reading and peak values on the slave unit will also be synchronized between the master unit and the slave unit. For example, when the peak value is cleared from the slave unit, the new peak value will be recorded at the slave unit and then mirrored to the master unit. When the peak value is cleared from the master unit, this operation will also be synchronized to the slave unit, and the peak value will be cleared.
- 2) Muting the alarms. When you press the SHIFT key to mute the alarm buzzer, it will only be effective to the buzzer on this unit. The buzzer on the other unit will continue sound until temperature left the alarm zone, or the SHIFT key on that unit is pressed.
- 3) Placing distance. Placing the master and the slave units too far or too close will result in bad signal reception on the master unit. Signal reception can be affect by distance, physical obstacles, and other factors. The master unit and the slave unit can be placed 100 feet away from each other in an open space.



Figure 6. Velcro mounting (left) and stainless steel plate mounting (right).

11. Placing and Mounting the Meter.

The meter should be placed in a working environment where temperature is -20-50°C (0-100°F). It should be placed away from high heat to protect the plastic housing and electronics. Two mounting options are provided:

- 1) A pair of Velcro fastener. The Velcro has a pressure sensitive adhesive backing. You can remove the protective film from the hook piece and stick it to the back of the meter (see Figure 6). Then remove the protective film from the loop piece and install it onto the wall. Please note that the pressure sensitive adhesive on Velcro is industrial grade with strong holding force. It needs to be stick on a solid surface. Don't put it on a drywall because it may peel off the paint if you decided to remove it later.
- 2) A stainless steel mounting plate. The plate allows the meter to be hung on a hook or a nail. It also allows the meter to be permanently mounted with a screw. The bottom part of the stainless steel mounting plate is covered with pressure sensitive adhesive. To install it onto the meter, peel off the pink colored releasing film; press it firmly onto the back of the meter (see figure 6).

NOTE: This equipment has been tested and found to comply with the limits for a Class B digital device, pursuant to part 15 of the FCC Rules. These limits are designed to provide reasonable protection against harmful interference in a residential installation. This equipment generates, uses and can radiate radio frequency energy and, if not installed and used in accordance with the instructions, may cause harmful interference to radio communications. However, there is no guarantee that interference will not occur in a particular installation. If this equipment does cause harmful interference to radio or television reception, which can be determined by turning the equipment off and on, the user is encouraged to try to correct the interference by one or more of the following measures:

- 1) Reorient or relocate the receiving antenna.
- 2) Increase the separation between the equipment and receiver.
- 3) Connect the equipment into an outlet on a circuit different from that to which the receiver is connected.
- 4) Consult the dealer or an experienced radio/TV technician for help.

Caution: Any changes or modifications to this device not explicitly approved by manufacturer could void your authority to operate this equipment.

This device complies with part 15 of the FCC Rules. Operation is subject to the following two conditions: (1) This device may not cause harmful interference, and (2) this device must accept any interference received, including interference that may cause undesired operation.

Auber Instruments

5755 North Point Parkway, Suite 99
 Alpharetta, GA 30022
 www.auberins.com

Email: info@aubersins.com Tel: 770-569-8420

Copyright 2007-2016, Auber Instruments All Rights Reserved.
 No part of this manual shall be copied, reproduced, or transmitted in any way without the prior, written consent of Auber Instruments. Auber Instruments retains the exclusive rights to all information included in this document.