

# Instruction Manual

## SYL-1813-24 Multifunction Autometer

### A. Specifications

- ◆ Power supply: DC24V (isolated)
- ◆ Power consumption: <2W
- ◆ Sampling rate: 4 samples/sec
- ◆ Accuracy: 0.2% full scale ±1
- ◆ Display range: -1999~9999
- ◆ Relay contact rating: 3A @ 220VAC
- ◆ Outside dimensions: 48×24×75mm
- ◆ Mounting cutout dimension: 45×22mm
- ◆ LED display: 0.28" red color
- ◆ Working condition: 0~50°C, ≤85%RH



### B. Front Panel

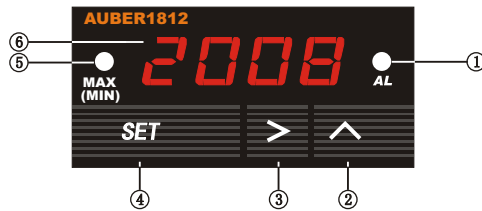

- ① Alarm and relay J1 indicator
- ② Up key
- ③ Shift key
- ④ Set key
- ⑤ Maximum and Minimum value indicator
- ⑥ Display window

1. AL on indicates alarm is on and J1 relay is pulled in (closed).
2. MAX(MIN) on when Display window shows the maximum value or the time of the Max. MAX(MIN) blinking when Display window shows the minimum value or the time of Min.
3. ">" shift key: In the parameter setting mode, press this key to select the digit to be changed. In the normal operation mode, press this key to change the display in the sequence as shown in the diagram below.

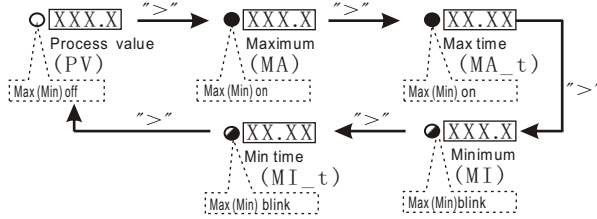

Please note that time is expressed in hour.minute (hh.mm) format.

4. "Λ" up key . In the parameter setting mode, press it to increase the displayed value. When displaying Max/Min, press and hold it for 3 seconds to clear the Max/Min stored. In normal function, this key has two functions, show operation time and change display brightness. Press and hold it down to show the operation time since on. Release the key to show the current temperature (process value). Each time the key is pressed, the display brightness will also be changed from bright to dim or from dim to bright.

### C. Parameter Setting

1, Basic Parameter (Press **SET** then input code 0089 to enter)

a) Basic Parameters description

Symbol	Description	Setting range	Initial	Note
<i>Inty</i>	Inty Input Type	See Table 1	<i>P</i>	
<i>dot</i>	dot Decimal point	0000~0.000	00.00	4
<i>PuL</i>	PuL Scale low	-1999~9999	00.01	4
<i>PuH</i>	PuH Scale high	-1999~9999	03.15	4
<i>PSb</i>	PSb Zero offset	-1000~1000	0	1
<i>PSbF</i>	PSbF Range coefficient	0.500~2.000	1.000	2
<i>CorF</i>	CorF Temperature unit	C : °C F : °F	F	
<i>FILt</i>	FILt Digital filter	0~3	0	3
<i>End</i>	End Exit			

- Note 1, for correcting the offset at zero: Display=measurement +PSb  
This parameter only apply to temperature sensors  
Note 2, for correcting the error at Max: Display=measurement x PSbF  
Note 3, Digital filter. 0=no filter. 1 weak, 2, medium, 3 strong.  
Note 4, These parameters define the scale boundary and resolution of the display value. They do not apply to temperature sensors.

【Table 1】 Input type options

Symbol	Input type	Range	Res.	Accy.	Impedance
<i>t</i>	TC, Type T	-200~400°C	1°C(F)	0.3%	100K
<i>r</i>	TC, Type R	-50~1600°C	1°C(F)	0.3%	100K
<i>J</i>	TC, Type J	-200~1200°C	1°C(F)	0.2%	100K
<i>WRE</i>	TC, WRe3-WRe25	0~2300°C	1°C(F)	0.2%	100K
<i>udo</i>	VDO water/oil	50~150°C	1°C(F)	0.3%	(0.2mA)
<i>S</i>	TC, Type S	-50~1600°C	1°C(F)	0.3%	100K
<i>P</i>	TC, Type K	-200~1300°C	1°C(F)	0.2%	100K
<i>E</i>	TC, Type E	-200~900°C	1°C(F)	0.2%	100K
<i>P100</i>	RTD, Pt100	-199.9~600.0°C	0.1°C(F)	0.2%	(0.2mA)
<i>Cu50</i>	RTD, Cu50	-50.0~150.0°C	0.1°C(F)	0.5%	(0.2mA)
<i>375r</i>	0~375 Ω Pressure			0.2%	(0.2mA)
<i>75nu</i>	0~75mV Current			0.1%	100K
<i>30nu</i>	0~30 mV			0.1%	100K
<i>5u</i>	0~5 V			0.1%	100K
<i>15u</i>	1~5 V			0.1%	100K
<i>10u</i>	0~10 V			0.1%	100K
<i>10nA</i>	0~10 mA			0.3%	150Ω
<i>20nA</i>	0~20 mA			0.2%	150Ω
<i>4-20</i>	4~20 mA			0.2%	150Ω

(TC, thermocouple sensor)

B) Basic Parameter setting (See 【Fig3】)

2, Alarm Parameter (Press **SET** then input code 0001 to enter)

a) Alarm Parameters description

Symbol	Name	Description	Range	Initial	Note
<i>AH1</i>	AH1	J1 pull in Value	-1999~9999	900	5
<i>AL1</i>	AL1	J1 drop out value	-199~9999	800	
<i>AH2</i>	AH2	J2 pull in Value	-1999~9999	900	
<i>AL2</i>	AH2	J2 drop out Value	-1999~9999	800	
<i>End</i>	End	Exit			

b) Alarm Parameter setting is similar to the Basic Parameters setting in Fig. 3 except access code is 0001 instead of 0089.

Note 5. Relay action setting (SYL-1813 does not contain J2 relay. Its setting (AH2, AL2) can be ignored).

- 1) Set AH1=AL1, relay is disabled.
- 2) Set AH1>AL1, relay is for high limit alarm. See Fig. 1
- 3) Set AH1<AL1, relay is for low limit alarm. See Fig. 2.

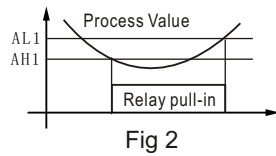
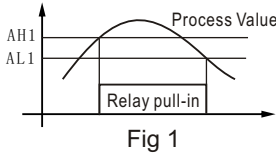

【Fig 3】 Basic Parameter setting flow chart:

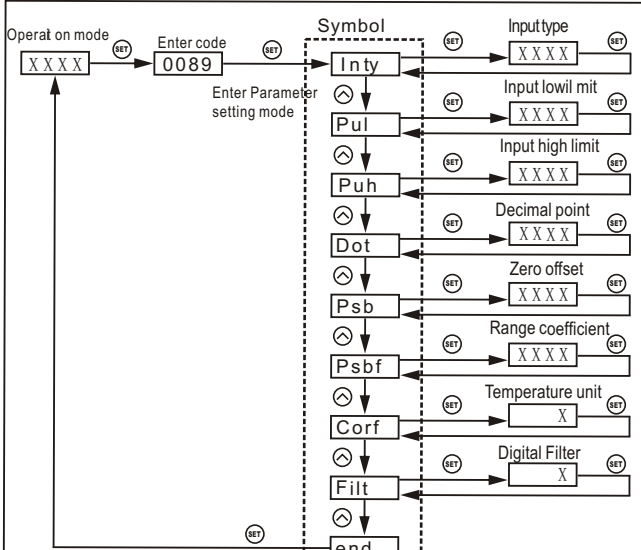

- Quick guide,
- 1) Press **SET** to enter setting mode.
  - 2) Use **⊙** and **⊖** to input code or parameter. 3) Use **SET** to confirm.
  - 4) Use **⊙** to select the next parameter.
  - 5) When no key is pressed for ~ 50 sec, the meter will return to normal mode.

3. Peak Value (Press **SET**, then input code 0037 to enter)

a) Peak value description

Symbol	Name	Description	Range	Initial	Note
$\bar{n} \bar{R}$	MA	Maximum value	0 n / 0 FF	0 n	6
$\bar{n} \bar{R} \text{-t}$	MA-t	Time of maximum	0 n / 0 FF	0 FF	
$\bar{n} \bar{l}$	MI	Minimum value	0 n / 0 FF	0 FF	
$\bar{n} \bar{l} \text{-t}$	MI-t	Time of minimum	0 n / 0 FF	0 FF	
$\bar{E} \bar{n} \bar{d}$	End	End			

Note 6, Peak function is inter locked.

- 1) When MA is turned off, MA-t can't be set.
- 2) When MI is turned off, MI-t can't be set.

b) Peak Value setting is similar to the Basic Parameters setting in Fig. 3 except access code is 0037 instead of 0089.

c) Reset the peak value

The peak values is stored in the memory even the meter is powered off. To reset them, change display to show MA, MA-t, MI or MI-t. Then, press and hold "Λ" key for 3 seconds. The display will show "----", indicating the memory (for all four parameters) is reset. The meter will start to catch the new peak after 2 seconds.

D. Terminal assignment

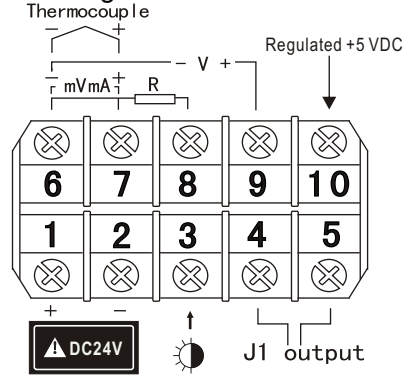

- 1) 1 and 2 are for power input
- 2) 4 and 5 are for alarm relay output. See Application example 1 below for how to use it.
- 3) 3 is for display brightness control. When connecting the illumination signal (+24V) to it, the brightness with synchronized with headlight. If not connected, the brightness can still be controlled by "Λ" up key.
- 4) 6, 7, 8 and 9 are for different types of signal input. Use 6 and 7 for thermocouple input. Use 6,7 and 8 for RTD sensor input. Use 6 and 9 for pressure sensor.
- 5) 10 outputs regulated 5VDC for powering pressure transducer.

E. Application examples

1) Exhaust Gas Temperature (EGT) measurement

The meter is preset for the EGT application. Wire the meter as the diagram below. It is ready to run.

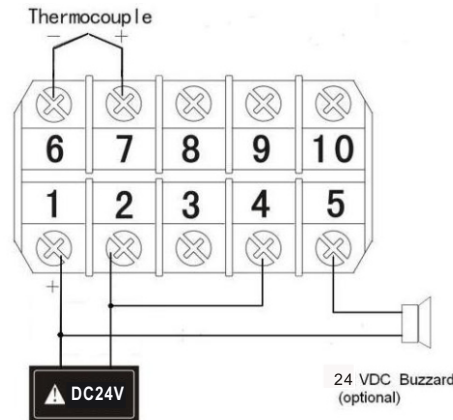

2) Set up for Auber 3 Bar MAP Sensor

- a) Connecting power to terminal 10, signal to terminal 9, and ground to terminal 6.
- b) Display in bar (0.01bar resolution). Enter the Basic Parameter setting mode with code 0089, i) Select input type, Inty, for 0-5 V input.
- c) Display in PSI (00.1psi resolution). Since 1 bar=14.5 psi, the set up needs to be modified as following. dot=000.0, PuL=000.2, PuH=045.7.

3) Water/oil Temperature Measurement with VDO 150°C/300°F Sender.

- a) Connecting VDO sender to terminal 8. Jump a wire between terminal 6 and 7; Jump another wire between terminal 2 and 6.
- b) Enter the Basic Parameter setting mode with code 0089, i) Set input type, Inty, for VDO input. ii) Set CorF to °C or °F,

**Auber Instruments**

730 Culworth Manor, Alpharetta, GA 30022 USA www.auberins.com

Tel 770-569-8420 info@auberins.com