

Instruction Manual

SYL-1813 Multifunction Automotive Gauge

Version 1.8 (May 2015)

A. Specifications

- Power supply: 12V DC (isolated)
- Power consumption: < 2W
- Sampling rate: 4 samples/second
- Accuracy: 0.2% full scale ± 1
- Display range: -1999 ~ 9999
- Relay contact rating: 3A @ 220VAC
- Outside dimensions: 48 x 24 x 75mm
- Mounting cutout dimension: 45 x 22mm
- LED display: 0.28"
- Working condition: 0 ~ 50°C, ≤ 85% RH

B. Front Panel



Figure 1. Front panel of SYL-1813.

- ① Display window
- ② Maximum and Minimum value indicator
- ③ Alarm and relay J1 indicator
- ④ Set key
- ⑤ Shift key
- ⑥ Up key

Description

1. LED display window to show readings from the sensor.
2. MAX (MIN) on when Display window shows the maximum value or the time of the Max. MAX (MIN) blinking when Display window shows the minimum value or the time of Min.
3. AL on indicates alarm is on and J1 relay is pulled in (closed).
4. Set key. To enter parameter setting mode, and to select or save parameters.
5. Shift key (>). In the parameter setting mode, press this key to select the digit to be changed. In the normal operation mode, press this key to change the display in the sequence as shown in the diagram below. Please note that time is expressed in Hour.Minute (hh.mm) format.

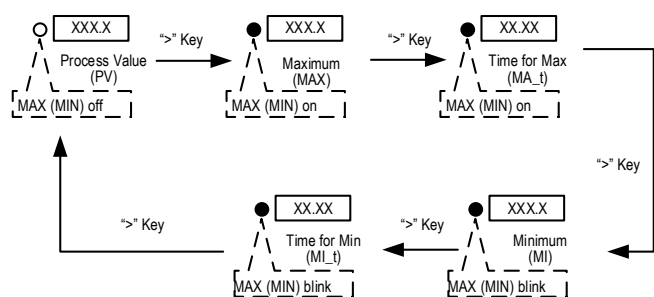

Figure 2. Check the peak values on the gauge by pressing Shift key.

6. Up key (^). In the parameter setting mode, press it to increase the displayed value. When displaying Max/Min, press and hold it for 3 seconds to

clear the Max/Min stored. In normal function, this key has two functions, show operation time and change display brightness. Press and hold it down to show the operation time since on. Release the key to show the current temperature (process value). Each time the key is pressed, the display brightness will also be changed from bright to dim or from dim to bright.

C. Terminal Assignment

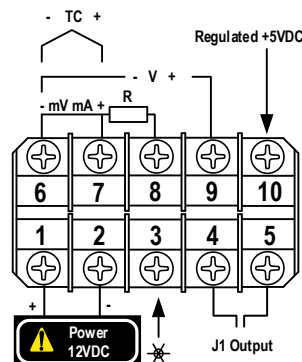

Figure 3. Terminal assignment of SYL-1813 gauge.

Description

1. Terminal 1 (+) and 2 (-) are for power input.
2. Terminal 3 is for display brightness control. When connecting the illumination signal (+12 V) to it, the brightness with synchronized with headlight. If not connected, the brightness can still be controlled by “^” up key.
3. Terminal 4 and 5 are for alarm relay output. See Application example 1 below for how to use it.
4. Terminal 6, 7, 8, and 9 are for different types of input signal. Use 6 and 7 for thermocouple input. Use 6, 7, and 8 for RTD sensor input. Use 6 and 9 for pressure sensor.
5. Terminal 10 supplies a regulated +5VDC for powering pressure transducer.

D. Parameter Setting

D.1 Basic parameter (press SET key then input code 0089 to enter)

D.1.A) Basic parameter description

Symbol	Name	Description	Setting Range	Initial Setting	Note
<i>InTy</i>	Inty	Input Type	See Table 1	<i>P</i>	
<i>dot</i>	Dot	Decimal Point	0000 ~ 0.000	<i>00.00</i>	4
<i>PuL</i>	PuL	Scale Low	-1999 ~ 9999	<i>00.00</i>	4
<i>PuH</i>	PuH	Scale High	-1999 ~ 9999	<i>03.15</i>	4
<i>PSb</i>	Psb	Zero offset	-1000 ~ 1000	<i>0</i>	1
<i>PSbF</i>	PSbF	Range Coefficient	0.500 ~ 2.000	<i>1.000</i>	2
<i>CorF</i>	CorF	Temperature Unit	C: °C; F: °F	<i>F</i>	
<i>FILT</i>	FILT	Digital Filter	0 ~ 3	<i>0</i>	3
<i>End</i>	End	Exit			

Note 1: For correcting the offset at zero: Display = measurement + PSb. This parameter only apply to temperature sensors.

Note 2: For correcting the error at Max: Display=measurement x PSbF.

Note 3: Digital filter. Filt = 0, no filter; 1, weak; 2, medium; 3, strong.

Note 4: These parameters define the scale boundary and resolution of the display value. They do not apply to temperature sensors.

Table 1. Sensor Input Type Options

Symbol	Input Type	Range	Res.	Accy.	Impedance
<i>t</i>	TC, Type T	-200 ~ 400°C	1°C (°F)	0.3%	100K
<i>r</i>	TC, Type R	-50 ~ 1600°C	1°C (°F)	0.3%	100K
<i>J</i>	TC, Type J	-200 ~ 1200°C	1°C (°F)	0.2%	100K
<i>WRe</i>	TC, WRe3 -WRe25	0 ~ 2300°C	1°C (°F)	0.2%	100K
<i>WDO</i>	VDO water/oil Temp	50 ~ 150°C	1°C (°F)	0.3%	(0.2mA)
<i>S</i>	TC, Type S	-50 ~ 1600°C	1°C (°F)	0.3%	100K
<i>K</i>	TC, Type K	-200 ~ 1300°C	1°C (°F)	0.2%	100K
<i>E</i>	TC, Type E	-200 ~ 900°C	1°C (°F)	0.2%	100K
<i>PT100</i>	RTD, PT100	-200 ~ 600°C	1°C (°F)	0.2%	(0.2mA)
<i>Cu50</i>	RTD, Cu50	-50.0 ~ 150.0°C	0.1°C (°F)	0.5%	(0.2mA)
<i>375r</i>	0~375Ω Pressure	Display range can be set to -1999 ~ 9999	16 bit A/D	0.2%	(0.2mA)
<i>75mV</i>	0~75mV Current			0.1%	100K
<i>30mV</i>	0~30mV			0.1%	100K
<i>5V</i>	0~5V			0.1%	100K
<i>1-5V</i>	1~5V			0.1%	100K
<i>10V</i>	10V			0.1%	100K
<i>10mA</i>	0~10mA			0.3%	150Ω
<i>20mA</i>	0~20mA			0.2%	150Ω
<i>4-20mA</i>	4~20mA			0.2%	150Ω

(Note: TC, thermocouples.)

D.1.B) How to change basic parameters (see Figure 4)

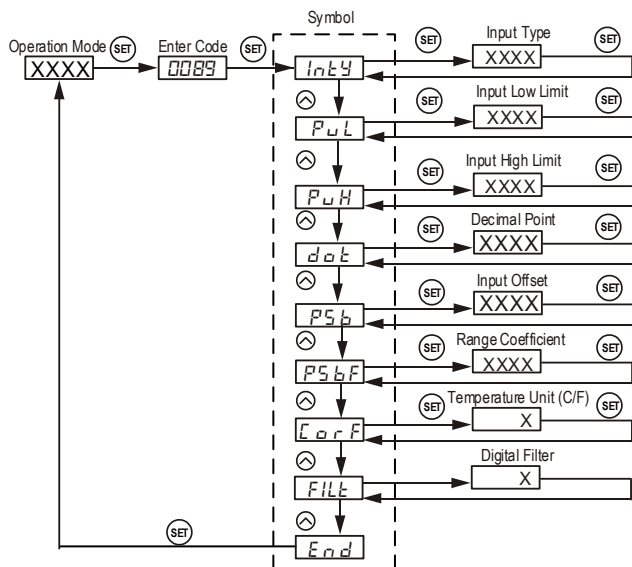

Figure 4. Basic Parameter Setting Flow Chart.

D.2 Alarm parameter (press SET then input code 0001 to enter)

D.2.A) Alarm parameters description

Symbol	Name	Description	Setting Range	Initial Setting	Note
<i>AH1</i>	AH1	J1 pull in value	-1999 ~ 9999	900	5
<i>AL1</i>	AL1	J1 drop out value	-1999 ~ 9999	800	5
<i>AH2</i>	AH2	J2 pull in value	-1999 ~ 9999	900	5
<i>AL2</i>	AL2	J2 drop out value	-1999 ~ 9999	800	5
<i>End</i>	End	Exit			

Note 5. Relay action setting (SYL-1812 does not contain J2 relay. Its setting (AH2, AL2) can be ignored).

- 1) Set AH1=AL1, relay is disabled.
- 2) Set AH1>AL1, relay is for high limit alarm. See Figure 5 (left).
- 3) Set AH1<AL1, relay is for low limit alarm. See Figure. 5 (right).

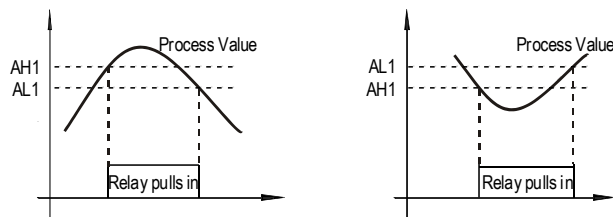

Figure 5. Reply (J1) action when the alarm is set as high alarm (left) and low alarm (right).

D.2.B) How to change alarm parameters

The procedure to change alarm parameters is similar to the procedure for basic parameter setting shown in Figure 4 except the access code is 0001 instead of 0089.

D.3. Peak value (press SET then input code 0037 to enter)

D.3.A) Peak value description

Symbol	Name	Description	Setting Range	Initial Setting	Note
<i>MA</i>	MA	Maximum value	On/off	On	6
<i>MA-t</i>	MA-t	Time of maximum	On/off	Off	6
<i>MI</i>	MI	Minimum value	On/off	Off	6
<i>MI-t</i>	MI-t	Time of minimum	On/off	Off	6
<i>End</i>	End	Exit			

Note 6, Peak function is inter locked.

- 1) When MA is turned off, MA-t can't be set.
- 2) When MI is turned off, MI-t can't be set.

D.3.B) How to change peak value parameters

The procedure to change the peak value settings is similar to the procedure for changing basic parameters in Figure 4 except access code is 0037 instead of 0089.

D.3.C) Reset the peak value

The peak values is stored in the memory even the meter is powered off. To reset them, change display to show MA, MA-t, MI or MI-t. Then, press and hold "Λ" key for 3 seconds. The display will show "----", indicating the memory (for all four parameters) is reset. The meter will start to catch the new peak after 2 seconds.

E. Application Examples

E.1 Exhaust gas temperature (EGT)

Our EGT probes are type K thermocouples. So the sensor type Inty should be set to "K". The gauge is preset for the EGT application. Wire the meter as the diagram below. It is ready to run.

(Continue on next page)

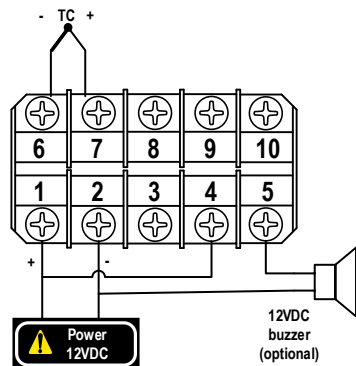

Figure 6. Wiring SYL-1813 with an EGT probe and an alarm buzzer.

E.2 Pressure transducers

Here is a brief description of how to set up the gauge for reading an Auber-103, 3 Bar MAP Sensor.

- Identify the power, signal, and ground cable on the pressure sender (please refer to the manual of pressure sender). Connecting power cable to terminal 10, signal cable to terminal 9, and ground cable to terminal 6.
- To display the pressure in bar (0.01bar resolution), enter the Basic Parameter Setting Mode with access code 0089, change the input type Inty to "0-5V" input, then set dot = 00.00, PuL = 00.01, and PuH = 03.15.
- To display the pressure in PSI (0.1PSI resolution), enter the Basic Parameter Setting Mode with access code 0089, change the input type Inty to "0-5V" input, then set dot = 000.0, PuL = 000.2, and PuH = 045.7.

E.3 Water/oil temperature sensor

If a VDO 150°C/300°F sender is used to read water/oil temperature, here is the basic settings.

- Connect the VDO sender to terminal 8; jump a wire between terminal 6 and 7; jump another wire between terminal 2 and 6.
- Enter the Basic Parameter Setting Mode with code 0089; set input type Inty = vdo; and set CorF to "C" or "F" for desired temperature unit.

Auber Instruments Inc.

5755 North Point Parkway, Suite 99,
Alpharetta, GA 30022
www.auberins.com
Email: info@auberins.com
Tel: 770-569-8420

Copyright 2007-2015, Auber Instruments All Rights Reserved.

No part of this manual shall be copied, reproduced, or transmitted in any way without the prior, written consent of Auber Instruments. Auber Instruments retains the exclusive rights to all information included in this document.