

Instruction Manual

HD220 Dual Output Programmable Humidity Controller

Version 1.0 (Sep, 2016)

1. Overview

This is a dual-output humidity controller with 8 programmable steps. It contains one humidity sensor and two independent outputs. One output is for humidifier and the other is for dehumidifier. The humidity control can be programmed to vary with different time step setting. Up to 8 humidity-time steps covering 33 days can be programmed. It can be used for tobacco dehydration, sausage curing, etc. By using both humidifying and dehumidifying, the humidity ratio can be controlled at a specific value regardless of whether it is in dry or wet environments.

This controller is a plug-n-play device. No extra wiring is needed for the humidifier or dehumidifier. Both humidifying and dehumidifying control modes contain simple on/off operation; they are similar to a mechanical humidistat but with much higher precision due to adjustable hysteresis band, precise sensor and digital read out.

Different operation humidity ranges of the two outputs can be set separately. Once the dehumidifying range is set, the controller program will automatically limit the humidifying range to prevent both outputs from being turned on at the same time.

This plug-n-play humidity controller is designed for high relative humidity (>85%) and condensing environments, where a slight drop in temperature may cause condensation and could damage other humidity sensors. This controller equipped with one of the most robust humidity sensors on the market. It can be fully recovered even immersed in water.

Wireless network connection capability is available in HD220-W. User can access humidity data and parameter settings of the controller from their smart phones or tablets. AuberSmart App is available on both iOS and Android platform. For details, please check the supplementary manual.

2. Specifications

Table 1. Specifications

Humidity Control Range	0 ~ 99.9% RH
Humidity Resolution	0.1% RH
Humidity Accuracy	4% RH
Sensor Working Temperature	- 40 ~ 197°F (- 40 ~ 90°C)
Humidity Control Mode	On/off control. Humidifying or dehumidifying
Humidity Control Output	15 A, 120 VAC or 240 VAC *
Timer Range	Each step: 0.1 to 99.9 Hrs or 1 to 999 Mins
Timer Resolution	0.1 Hours or 1 Minute
Max Programmable Time	799.2 hours or 33.3 days (for total 8 steps)
Audio Alarm	High and low limit
Controller Operating Environment Temperature	0 ~ 50°C
Dimension	91 mm x 140 mm x 46 mm
Input Power	85 ~ 242 VAC, 50 Hz / 60 Hz

Sensor Cable Length	6 ft (2 m)
Power Cable Length	3 ft (1 m)
Warranty	One (1) year

* Please note: although both humidity and dehumidity output channel can handle up to 15A, the total power can be handled by this controller is limited to 1500 Watts due to the restriction of the input power cord.

3. Front Panel



Figure 1. Front Panel.

Measured Humidity Window: In normal operating mode, this window shows measured humidity. In parameter setting mode, this window shows parameter name.

Set Humidity Window: In normal operating mode, this window shows set humidity. In parameter setting mode, this window shows parameter value.

RUN Indicator: This green LED indicator lights up when the controller is running in multi-step mode. It will be off when the controller runs in single-step mode.

WiFi Connection Indicator (for HD220-W only): This blue LED indicator shows WiFi connection status. Please check supplementary manual for details.

SET Key: Access the program settings and parameter settings.

Up Key: Increase parameter value.

Down Key: Decrease parameter value.

PAUSE/STOP Key: Short press it to pause the program; long press it for 4 seconds to stop the program (works only when the program is paused).

START Key: Start or resume executing the program.

STEP Key: Check the current step; or jump to a different step.

Mute Key: Silent the alarm buzzer.

Dehumidifier Socket: Supply power to dehumidifier.

Dehumidifier Indicator: This red LED indicator lights up when the dehumidifier socket is energized.

Humidifier Socket: Supply power to the humidifier.

Humidifier Indicator: This green LED indicator lights up when the humidifier socket is energized.

4. Basic Operation

Here are the basic operating procedures to use this controller. To fully understand the functions on this controller, please read the entire manual.

- 1) Connect the humidity sensor to the sensor socket that is located on the bottom of the controller. Please check the alignment of the slot on the plug with the key on the socket. (See section 12 for details.)
- 2) Plug the controller's power cord to a wall outlet.
- 3) Set up the program and system parameters. Please read the rest of this manual for details.
- 4) Connect the humidifying and dehumidifying devices to the output sockets on this controller.
- 5) Press START key to start running the program.

5. Mode Selection

This controller has 5 different modes: program run, program hold, program stop, parameter setting, and programming mode. Before powering on the controller, please connect the sensor cable to it. If no sensor is connected, the controller will show error code "Err", indicating no sensor is detected.

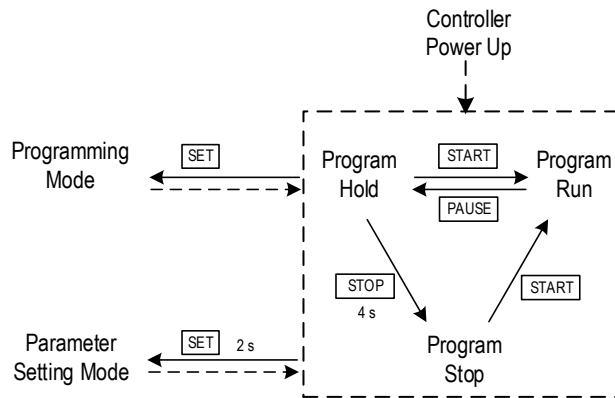

Figure 2. Switching between different modes.

Program Running: The controller executes the saved program. The green indicator RUN is lit, and the timer is running. The display window should show the current humidity reading. The controller will send power to its humidifying/dehumidifying outlets to regulate humidity. When the program is running, press PAUSE key will put the controller to Program Hold mode.

Program Holding: Controller pauses the time but it still regulates the humidity at the current set value. The RUN indicator is off. The display window flashes between the measured humidity value and "Hold". To resume the program, press START key. To completely stop the program, hold the STOP key for 4 seconds.

Program Stop: The execution of the program is terminated. Controller outputs are deactivated and timer is also stopped. The RUN indicator is off. The display window flashes between the measured humidity value and "Stop". To start the program, press the START key. The controller will start regulating the program from the first step.

Programming Mode: Review and edit humidity set value and set time for each steps. When the controller is in Program Run, Hold, or Stop mode, press SET key to enter the Programming mode. Please see figure 4 for details.

Parameter Setting Mode: Review and edit system parameters. When the controller is in Program Run, Hold, or Stop mode, hold the SET key for 2 seconds to enter the Parameter Setting mode. Please see figure 3 for details.

6. Parameter Setup

Please see Table 2 for a list of parameters and see Figure 3 for the flow chart of how to set the parameters. Please note that parameters will remain unchanged unless you press set key to confirm the change.

Table 2. List of Parameters.

Code	Description	Setting Range	Initial	Note
AH	Deviation high alarm	0 ~ 99.9	20.0	1
AL	Deviation low alarm	0 ~ 99.9	20.0	1
HY	Humidity Control Hysteresis Band	0 ~ 99.9	1.0	2
HYd	Dehumidifier Hysteresis Band	0 ~ 99.9	5.0	3
HYH	Humidifier Hysteresis Band	0 ~ 99.9	5.0	4
oFS	Humidity Offset	-9.9 ~ 9.9	0	5
AS	Anti-short Cycle Delay (only for dehumidifying)	M 0 ~ M 99 (0 ~ 99 min)	M 6	6
PrG	Program Modes	on, off	ON	7
A-M	Power Outage/Startup Modes	S, M, C	S	8
SFA	Sensor Failure Operation	0-0, 0-1, 1-0	0-0	9
TIM	Time unit	H, M	H	10
PSD	App access password	000 - 999	666	11

Note 1. AH, Deviation high alarm; AL, Deviation low alarm: Assuming measured humidity is PV and set humidity is H. When PV - H is above AH, the built-in buzzer will turn on (deviation high alarm); when H - PV is above AL, the built-in buzzer will turn on (deviation low alarm). User can mute the alarm by momentarily pressing the Mute key. The alarm will remain inactive until the process value moves out of the alarm zone. Both alarms are deviation alarms, i.e., if AH = 20%, AL = 30%, and the Set Humidity (H) is 50% RH, the alarm will be activated if the humidity is above 70% or below 20%. The alarm function is suppressed at powering up or when the program is jumped from one step to another step. It will be activated automatically once the measured humidity enters the none-alarm zone (between H - AL and H + AH).

Note 2. Hy, Humidity Control Hysteresis Band, or Humidity Control Dead Band: This parameter set up a dead band (between H - Hy and H + Hy) within which either the humidifier or dehumidifier will not work. The minimum value for Hy is 0.5. The Hy value should not be too small if the system has sluggish response. Otherwise, it may result in the humidifier and the dehumidifier working against each other, wasting energy and causing oscillation.

Note 3. Hyd, Dehumidifier Hysteresis Band: This is the differential band between turn on and turn off the dehumidifier. It is set to the higher side of the dehumidifier set point (H + Hy). The dehumidifier will turn on when humidity is above (H + HY + Hyd), and turn off when humidity is below (H + Hy). For compressor based dehumidifier, the Hyd value should not be set too small to prevent frequent cycling.

Note 4. HyH, Humidifier Hysteresis Band: This is the differential band between turn on and turn off the humidifier. It is set to the lower side of the humidifier set point (H - Hy). The humidifier will turn on when humidity is below (H - HY - HyH), and turn off when humidity is above (H - Hy). For example, if Set Humidity H = 50%, Hy = 5%, Hyd = 3%, HyH = 2%, then the humidifier will turn on when process humidity is lower than 43% (H - Hy - HyH) and turn off when process humidity is above 45% (H - Hy). The

dehumidifier will turn on when process humidity is above 58% (H + Hy + Hyd) and turn off when process humidity drops below 55% (H - Hy).

Note 5. OFS, Humidity Offset:

OFS (Humidity Offset:) is used to compensate the error produced by the sensor or input signal itself. For example, if the unit displays 37% when the actual humidity is 32%. Set parameter OFS = - 5 will make the controller display 32%. The displayed process humidity = actual measured humidity + OFS.

Note 6. AS, Anti-short Cycle Delay:

The Anti-short is the delay time to turn on the dehumidifier. If the dehumidifier is compressor based, compressor should not be turned on immediately when it is at high pressure (just after turned off). Otherwise, it may shorten the life of compressor. The Anti-Short cycle delay function can be used to prevent the rapid cycling of the compressor. It establishes the minimum time that the compressor remains off (after reaching cutout) before turns on again. The delay overrides any controller demand and does not allow the compressor to turn on until the set time-delay value has elapsed. It gives time to release the refrigerant pressure through evaporator. It typically set to 4- 6 (minutes). The unit is in minutes. This setting is only valid for dehumidifying control.

Note 7. PrG, Program Mode:

When PrG is set to "ON", user can program up to 8 steps (Section 5). When set it to "OFF", this multi-step function is disabled and controller is in single step mode. User can only set "H-1" value (without timer t-1) when disabled. Please be aware that if your controller is in single step mode, the green "RUN" indicator will be off at all time. The start key, pause key and STEP key are disabled. You can check the dehumidifier indicator (red on the left) and humidifier indicator (green on the right) for the socket output status. When the light is on, the corresponding socket will be activated.

Note 8. A-M, Power Outage/Startup Mode:

This parameter determines what the controller should do in an event of power interrupt or outage. It also decides how the controller starts the program while powered up. A-M can be set to three modes: C, S and M.

Mode C. After being powered on, the controller will continue the program from the where it was powered off. For example, if step 3 is set for 40% and 5 hours, the power was interrupted at 2.1 hours. Then, when the controller power up, the controller will continue to control at 40% for 2.9 hr.

Mode S. The controller will run the program from step 1 every time the controller is powered up. This is suitable for situations where the power never fails, or when the program mode "PrG" is set to "off".

Mode M. The program will be held at the step at which the controller was powered off. The controller will hold the humidity at the set value. The controller lower display will flash "hold" and process humidity alternatively. This mode is suitable for situations where the operator's attention is needed after power interruption occurs.

Note 9. SFA, Sensor Failure Operation:

The SFA defines how the output would be if the sensor fails. It can be set to 0-0, 0-1 or 1-0. Please refer to Table 3 for details. For example, in some applications, you may want the dehumidifier to be working and the humidifier to be off when sensor fails. Hence you need to set SFA to "1-0".

Table 3. Output of the controller when sensor fails.

SFA	Controller output when sensor fails
0-0	dehumidifier off, humidifier off
1-0	dehumidifier on, humidifier off
0-1	dehumidifier off, humidifier on

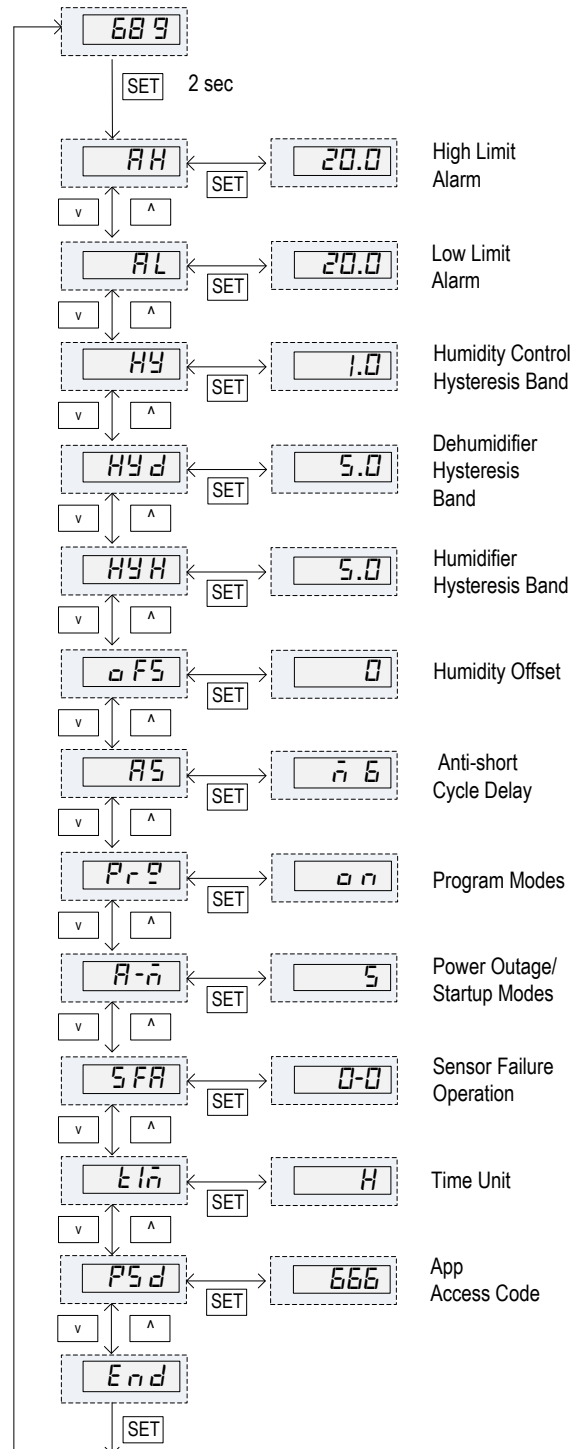

Figure 3. Flow chart of setting up parameters.

Note 10. TIM, Time unit setting:

The Time defines the timer unit setting for its timer function. It can be set to hour (H) or minute (M). By default, Time is set to H.

Note 11. PSD, App access code (for HD220-W model only):

To prevent the operator from changing the settings by accident over the AuberSmart App, this access code is required. The default value is 666.

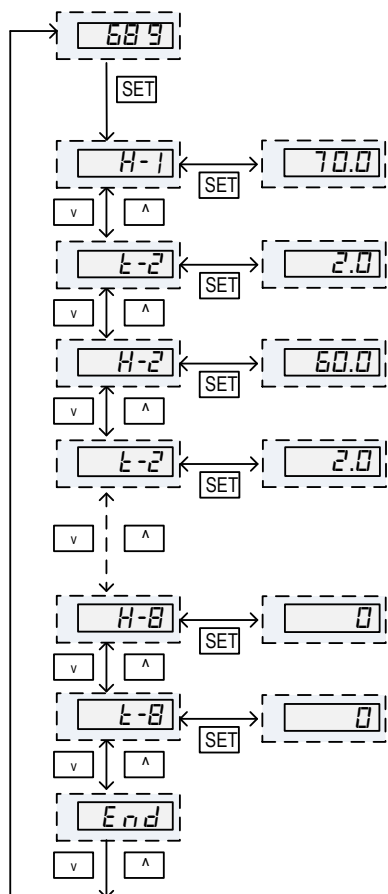

Figure 4. Flow chart of setting up control program.

To program the humidity profile, briefly press SET key once. The display will show "H-1". Press SET key again then it will show the humidity set value for step 1. Use ▲ or ▼ key to adjust the humidity to the desired value. Then press SET key again to save the change and exit "H-1" setting. Use ▲ key to go to next the parameter "t-1", the preset time for step 1. Press SET key to view the value, use ▲ or ▼ key to adjust it to the desired value, and then press SET key again to save the change and exit "t-1" setting. Use ▲ key to go to the next step, or use ▼ key to go back to the previous parameter. Repeat operation till you finish programming all necessary steps. You can set the time for rest of the steps to zero so that the controller will skip these steps. Go to "End" to exit the program editing mode.

Note: The set value will not be saved unless SET is pressed. If no adjustment is needed for any followed steps, you can go to "End" by pressing the ▲ key and then the SET key. The controller will also return to the normal operating mode if it is left alone for 10 seconds.

7. Check the Status

Step Running Time: how much time has passed since the beginning of the current step. You can check the Step Running Time while the controller is in the Program Running Mode:

- 1) Short press the STEP key once so the display window will show the current step number "P - X".
- 2) Wait about 1second for the step running time to appear in the display window.
- 3) Press STEP key again to check the Total Power-on Time (see below) or not touching any key for 10 seconds so that the display window will show the humidity reading again.

Total Power-on Time: how much time has passed since the controller is powered on. You can check the Total Power-on Time in Program Running, Holding, or Stop Mode:

- 1) Short press the STEP key twice, you can see "tol" shown in the display window shortly, and then the Total Power-on Time will be shown.
- 2) Press STEP again to return to humidity reading.

Once the whole program is finished, the display will show "End" and buzzer will be ON. Press start key once to restart the program.

8. Program Jump

This controller allows its user to skip part of the program by jumping to a specified program step. For example, the controller has run 3 minutes in its 2nd step. If the user wants to skip the rest of the 2nd step and the entire 4th step, then the user can jump to step 4.

To jump to a specified step:

- 1) Put the controller in either Program Hold or Stop Mode.
- 2) Press STEP key so the controller will flash "J-X", where "J" indicates this operation is for jumping to a step, "X" is the step number. Use UP or DOWN arrow key to increase or decrease the step number to desired value, then press START key to confirm. The display window will show J̄ P̄ ("JUMP") briefly to confirm that jump is accomplished. Then controller will execute the step, RUN indicator will lit, and display window should show humidity reading.

9. Alarm Buzzer

The controller has a build-in buzzer. Under the following situations, the alarm buzzer will be triggered:

- 1) When the humidity alarm is triggered, the buzzer will keep on beeping until the MUTE key is pressed.
- 2) When a program step (other than the 8th step) is finished, the buzzer will beep twice.
- 3) When the entire program is finished (the 8th step), the buzzer will keep on beeping until the MUTE key is pressed.

When the alarm buzzer is beeping, you can press MUTE key to mute the alarm.

10. Quick Operation Guide

- If you see "Err" message in the display window, check the sensor connection.
- To run the program: if the controller is in Hold or Stop mode, press START key. The RUN indicator should lit up.
- To hold the program: when the program is running (RUN indicator on), short press PAUSE key to put the program on hold.
- To stop the program: put the program to Hold mode, then long press the STOP key for 4 seconds until you see "Stop" in the display window.
- To set up program steps: press SET key.
- To set up system parameters: long press SET key for 2 seconds.
- To mute the alarm: press MUTE key.

- To check the current step number and the step running time: in the program running mode, press STEP key once, the display will show "P-X", where X is the current step number, then the display window will show the elapsed time in the current step.
- To check the total time since the controller is powered up: in the program running mode, press STEP key twice. The display window will show "toL" and then it will display the total time since controller is powered up.
- To start from a specific step (or jump to a specific step): when the program is on hold or stopped, press STEP key once, it will show "J-X", where X is the current step number. Use the UP or DOWN key to change the step number to the desired value, then press START key to confirm. The display will show $\overline{J} \overline{P}$ ("JUMP") for a second and then the controller will start executing the specified program step.

11. Connect the Sensor to the Controller

The connector of sensor contains a slot for fitting pin connection. It also has a spring lock to prevent disconnections from accidental pulling on the cable.

To install the sensor to the controller: 1) Identify the key on the male sensor connector (Figure 5, a) and the notch on the female connector (Figure 5, b). 2) Hold the tail of the female connector, align the notch and the key, and push the female connector forward.

To remove the connector, hold the spring loaded collar on the female connector and pull it back. Please see Figure 6.

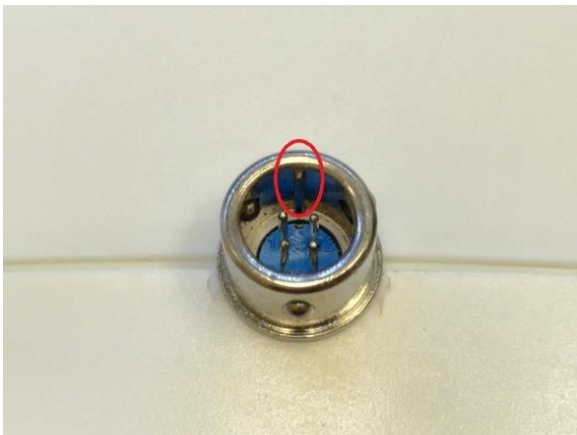

(a)



(b)

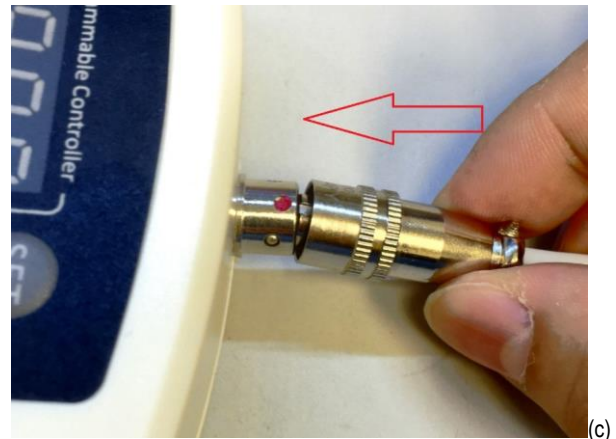

(c)

Figure 5. Install the sensor.



Figure 6. Remove the sensor.

Auber Instruments

5755 North Point Parkway, Suite 99

Alpharetta, GA 30022, USA

www.auberins.com

E-mail: info@auberins.com Tel: 770-569-8420

Copyright 2007-2016, Auber Instruments All Rights Reserved.

No part of this manual shall be copied, reproduced, or transmitted in any way without the prior, written consent of Auber Instruments. Auber Instruments retains the exclusive rights to all information included in this document.