

Quick Guide for Boost Gauge Installation

A. Installation of Auber 103 or the GM 12223861 3 bar MAP sender.

1) Wiring the sensor as shown in Fig 1. Connecting power lead to terminal 10, signal lead to terminal 9, and ground lead to terminal 6. The 12V DC buzzer is optional.

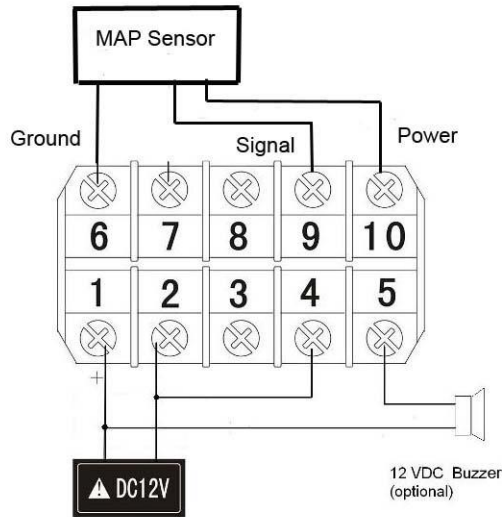

Fig 1. Wiring diagram.

2) Set the parameters for displaying the pressure with 0.01 bar resolution. Enter the Basic Parameter setting mode with code 0089, a) Set input type, **Inty**, for 0-5 V input. b) Set the decimal point, **dot**= 00.00 (this step needs to be done before set PuL and PuH). c) Set the PuL=00.01. PuH=03.15.

3) If you like to display the pressure unit in PSI (00.1psi resolution) instead of Bar, “2)” needs to be modified. Enter the Basic Parameter setting mode with code 0089, a) Set input type, **Inty**, for 0-5 V input. b) Set the decimal point, **dot**= 000.0 (this step needs to be done before set PuL and PuH). c) Set the PuL=000.2. PuH=045.7.

4) To set the alarm on at 2.50 Bar and off at 2.48 Bar, Enter code 0001 to set AH1=2.50 and AL1=2.48. The detail can be found in section C 2 of the instruction manual.

5) If you want display zero at atmosphere pressure, shift the PuL and PuH down be one atmosphere pressure unit (standard atmosphere =1.00bar or 14.5PSI).

For display in Bar, PuL = 0.01076-1 = -0.99, PuH = 3.154-1 = 2.15

For display in PSI, PuL= - 14.4, PuH = 31.2

Note. Since this is an absolute pressure sensor instead of gauge pressure sensor, the meter will not display zero pressure unless the absolute barometric pressure at the sensor location is 1.00 bars (or 14.5PSI). The barometric pressure reported from location weather station is the pressure converted to the sea level, or relative barometric pressure. It is not the absolute barometric pressure at the local altitude.

B, Discussion

- 1) Since the output specification of Auber 103 and the GM 12223861 MAP sender are identical, this instruction can be used for both of them.
- 2) If you have a pressure sensor (sender, transducer or transmitter) that has different output specification, you need to find the value of PuL and PuH. Appendix 1 shows how the Auber 103 sensor parameter is determined. If you need help, please email us the specification of your sensor to info@auberins.com
- 3) The peak holding function is set for displaying the Maximum pressure only. To display the peak pressure from the last run, or display the pressure in the peak holding mode continuously, press the ">" key once. The MAX (MIN) LED will be on, indicating the display is in the peak mode. Press ">" again to change back to display the current pressure. Press and hold "Λ" for 3 second will reset the memory. Three additional peak parameters are turned off. They are, the time that the maximum pressure was recorded, the minimum pressure and its recording time. If you want see them, use code 0037 to turn on these functions. The detail can be found in section C3 of the instruction manual.
- 4) This instruction is for the SYL-1812R1 that has the 5 V power supply (for the pressure sensor) enabled at terminal 10. This meter is listed separately from the standard SYL-1812R for EGT. If you have an older version of SYL-1812R or the version for the EGT application, you need to get the 5 V out to terminal 10. Please ask factory for instruction on how to do it.

C. Appendix 1,

Example. Calculating the set up parameters for GM 12223861 MAP sensor.

For a pressure sensor that is powered by 5 V DC, the linear range of the output signal will be higher than 0V and lower than 5 V due to the nature of mechanics and electronics. GM published data is 0.4 bar = 0.619V, 3.04 bar =4.818 V. What these data tell us is that the sensor has a linear output between 0.619 and 4.818 V when the input signal is between 0.4 and 3.04Bar, In other words, within this range, the relationship between pressure and output voltage can be represented by

$$V = a \times P + b \quad (1)$$

Where P is the pressure, V is the voltage. **a**, is the slop, and **b** is the intersection at zero pressure,

Because the meter is set for 0-5V linear input, we need to find out what is the pressure when we extend the equation 1 from 0.619-4.818V to the 0 and 5 V.

Calculating slop **a** and intersection **b**

$$a = (4.818 - 0.619) / (3.04 - 0.4) = 1.5905$$

$$b = V - a \times P = 4.818 - 3.04 \times 1.5905 = -0.01712$$

$$\text{So, } V = 1.5905P - 0.01712, \text{ or } P = (V + 0.01712) / 1.5905$$

Therefore, at 0 V, P = 0.01076; at 5 V, P = 3.154.

To display in absolute pressure,

Set **dot** to **00.00**, **PuL=0.01**, **PuH=3.15**

To display the pressure with PSI units instead of Bar, multiply the number by 14.5
(1bar=14.503PSI)

Set **dot** to **000.0**, **PuL=0.2**, **PuH=45.7**.

Auber Instruments Inc.

5755 North Point Parkway, Suite 99,
Alpharetta, GA 30022

www.auberins.com

Email: info@auberins.com

Tel: 770-569-8420

Copyright 2007-2015, Auber Instruments All Rights Reserved.

No part of this manual shall be copied, reproduced, or transmitted in any way without the prior, written consent of Auber Instruments. Auber Instruments retains the exclusive rights to all information included in this document.