

# Instruction Manual

## SYL-1613 Temperature Controller for Charcoal Smoker

Version 1.2

### 1. Features

This PID controller is for controlling the temperature of charcoal smoker. It will regulate the on/off time interval of a 12VDC blower to stabilize the temperature in the charcoal smoker. It has built-in solid state relay that can drive a 12V DC operated blower up to 60 CFM. It has a built-in buzzer that can be set for both low limit and high limit alarm. The system includes a controller, an AC to 12V DC adaptor, a K type thermocouple. Also included is power plug that fits the control output jack. User needs to install the plug to a 12V DC operated blower with adequate wind speed (5 CFM Fan is the most common for a small smoker).

### 2. Specifications

- ◆ AC adaptor: 100-240V, 50/60Hz input. 12 VDC, 1 Amp output.
- ◆ Power consumption: <2W
- ◆ Sampling rate: 4 samples/second
- ◆ Accuracy: 0.2% full scale
- ◆ Display range: -320~2400°F, or -200~1300°C
- ◆ SSR output for Fan: 12VDC, 1 Amp\*
- ◆ LED display: 0.39 inch, red
- ◆ Control Mode: PID, On/off, Limit.
- ◆ Alarm: Two set points with buzzer sound.
- ◆ Sensor: K type thermocouple, -300~550°F (-200~300°C).\*\*
- ◆ Dimension: 3x5x1.2" (78x120x28.5mm)

\* Up to 3 Amp can be supplied when more powerful power supply is used.  
 \*\* Eight other types of thermocouple can also be accepted (see table 4)

### 3. Front Panel

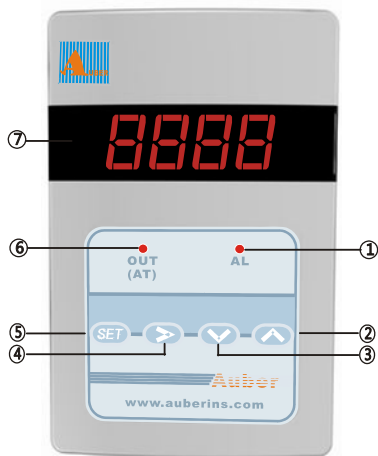
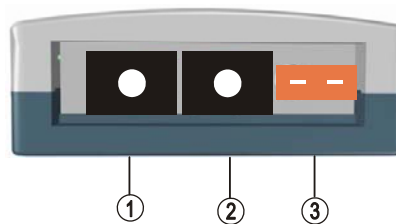

Figure 1. Front panel

- ① AL-Alarm Indicator
- ② Value increment/Select next parameter
- ③ Value decrement/Select previous parameter
- ④ Digit shift/Alarm mute/Auto-tune
- ⑤ Set/Confirm
- ⑥ OUT-SSR output indicator  
(AT)-Blinking during auto-tune process
- ⑦ Parameter display

### 4. Connecting the Controller

Figure 2 shows the terminals of the controller. Connect the AC to 12V DC power adapter to the terminal 1 and wall outlet. Connect the fan connector to terminal 2. The polarity for this socket is center pin positive (+), outer collar negative (-). Connect the K thermocouple to terminal 3. Please note that thermocouple connector also has polarity. The wide blade should go to the wide slot.



- ① POWER-12V Power supply input
- ② OUT- Fan control output
- ③ INPUT-Temperature probe input

Figure 2. Terminals (back view)

### 5. Parameter Setting

#### 5.1. Temperature setting and Alarm setting (accessed by code 0001)

Table 1. Temperature and alarm parameters

| Symbol | Description             | Range                                      | Initial | Note   |
|--------|-------------------------|--|---------|--------|
| SV     | Target temperature      | Arbitrary value within the measuring range | 200     | Note 1 |
| AH1    | Alarm 1 on temperature  |  | 250     | Note 2 |
| AL1    | Alarm 1 off temperature |  | 249     |        |
| AH2    | Alarm 2 on temperature  |  | 250     |        |
| AL2    | Alarm 2 off temperature |  | 250     |        |
| End    | Exit                    |  |         |        |

Note 1. Set Temperature.

There are two ways to set the target temperature.

a. During the normal operation mode, press  $\Lambda$  or V once to switch the display from process value (PV) to set value (SV, or target temperature). The display will start to blink. Press  $\Lambda$  or V again to increase or decrease the SV. When finished, wait 8 seconds and the settings will take effect automatically (the display will stop blinking).

b. Press SET key once. Use  $\gt$ ,  $\Lambda$  and V keys to enter code 0001. Press SET key to confirm, then the display would be SV (SV). Press SET key again to display the SV setting. Use  $\gt$ ,  $\Lambda$  and V keys to enter the new SV value and press SET to confirm. Press V key to change the display to END. Then, press SET to exit. You can also ignore the steps after confirmation of SV. The controller will return to normal operation mode automatically if no key is pressed for 1 minute. The flow chart below shows how to set the SV and alarms in details.

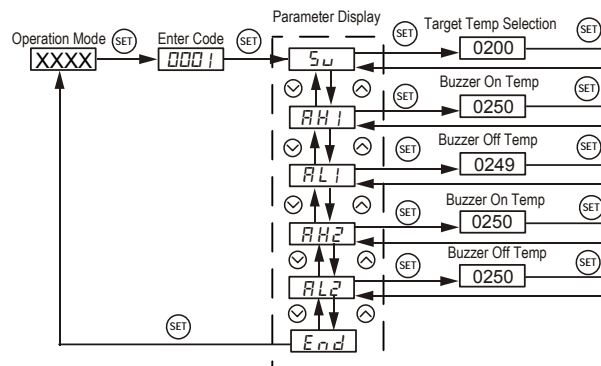

Figure 3. Flow chart for how to set target temperature and alarm.

**Note 2. Set alarm**

The controller offers two alarms that can be set to turn on the buzzer at specific temperatures. The first alarm is controlled by parameters AH1 and AL1. The initial setting will turn on the buzzer at 250°F and off when temperature drops below 249°F. The second alarm is controlled by parameters AH2 and AL2. The initial setting of the second alarm is deactivated. It can be set as low alarm to send warning when charcoal is low.

AH1 and AH2 are the temperatures to turn buzzer on; AL1 and AL2 are the temperatures to turn buzzer off. When AH1(2) >AL1(2), the alarm is set for absolute high alarm as shown in Figure 4 below. When AH1(2) <AL1(2), the alarm is set for absolute low alarm as shown in Figure 5 below. When AH1(2)=AL1(2), the alarm is deactivated.

Example, if AH1=250, AL1=249, when the temperature goes up to 250°F, the buzzer will be on; when the temperature drops down to 249°F, the buzzer will be off. If AH2=180, AL2=185, when the temperature drops down to 180°F, the buzzer will be on; when the temperature goes up to 185°F, the buzzer will be off.

User can press the shift key (>) to temporarily mute the buzzer sound of alarm 1. The alarm will buzz again if the alarm set temperature is reached again. If you use the low limit alarm, we suggest you set alarm 1 as the low limit alarm because you may need to silence it when start cold or open the lid. To permanently deactivate the alarm, set AH1=AL1 or AH2=AL2. Please see flow chart in Figure 3 on how to set the value.

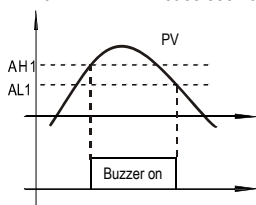

Figure 4. Absolute high alarm

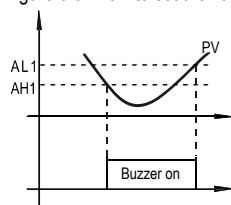

Figure 5. Absolute low alarm

The contents below are for reference and advanced applications. Most BBQ smoker users do not need to read beyond this point.

**5.2 PID parameter setting** (accessed by code 0036)

The values of P, I and D parameters are critical for good response time, accuracy and stability of the system. The values of the PID parameters have been optimized for charcoal grill application. User should not change it unless the result is not satisfactory. In that case, you can use the Auto-Tune function to automatically determine these parameters. If auto-tuning result is not satisfactory, you can manually fine-tune the PID constants for improved performance.

Setting PID parameters is similar to the setting of the Temperature and Alarm Parameter as shown in the flow chart of Figure 3. The difference is that these parameters are accessed by enter code 0036 instead of 0001.

Table 2. PID and relevant parameters

| Symbol | Description             | Setting Range | Initial | Note   |
|--------|-------------------------|---------------|---------|--------|
| P      | Proportional Constant   | 0.1~99.9(%)   | 1.2     | Note 3 |
| I      | Integral Time           | 2~1999(Sec)   | 300     | Note 4 |
| d      | Derivative Time         | 0~399(Sec)    | 70      | Note 5 |
| SouF   | Damp Constant           | 0.1~1.0       | 0.7     | Note 6 |
| ot     | Cycle Rate              | 2~199(Sec)    | 7       | Note 7 |
| FILt   | Digital Filter Strength | 0~3           | 0       | Note 8 |
| End    | Exit                    |               |         |        |

**Note 3. Proportional Constant (P):** When P increases, the system is more stable. When P decreases, the system is less stable. If the P is too small, the system would be oscillatory or even non-convergent.

**Note 4. Integral time (I):** Brings the system up to the set value by adding a constant to the output that is proportional to how far the process value (PV) is from the set value (SV) and how long it has been there. When I decreases, the response speed is faster but the system is less stable. When I increases, the respond speed is slower, but the system is more stable. When I is 0, then it turns to be PD control.

**Note 5. Derivative time (d):** Responds to the rate of PV change, so that the controller can compensate in advance before |SV-PV| gets too big. A larger number increases it's action. Setting d-value too small or too large would decrease system stability, cause oscillation or even non-convergence.

**Note 6. Damp constant (SouF):** The parameter is controlled by the artificial intelligence of the controller. This constant helps the PID control quality. When its value is too high, the system will be over damped. When its value its too low, the system may overshoot.

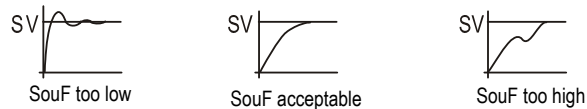

Figure 6. Damp constant

**Note 7. Cycle rate (ot):** It is the time period that the controller uses to calculate its output. The initial value is set to 7 seconds for charcoal smoker control. Short time causes the fan to pulse at higher frequency. Longer time may reduce the quality of control

**Note 8. Digital Filter (Filt):** can be set as 0, 1, 2, 3. Filt=0, filter disabled; Filt=3, strongest filtering effect. Stronger filtering increases the stability of readout display, but causes more delay in the response to changes in temperature.

**5.3 System Configuration Parameters** (accessed by code 0089)

Table 3. System configuration parameter setting

| Code | Description         | Setting Range         | Initial | Note    |
|------|---------------------|-----------------------|---------|---------|
| InTy | Input Sensor Type   | See Appendix          | K       |         |
| outy | Control Output Mode | 0, 1, 2, 3, 4, 5, 6   | 2       | Note 9  |
| Hy   | Hysteresis Band     | 0~9999                | 3       | Note 10 |
| Atdu | Autotune Offset     | 0~200                 | 10      | Note 11 |
| PSb  | Input Offset        | -1000~1000            | 0       |         |
| rd   | Control Function    | 0: heating 1: Cooling | 0       | Note 12 |
| CorF | Display Unit        | 0: °C 1: °F           | 1       | Note 13 |
| End  | Exit                |                       |         |         |

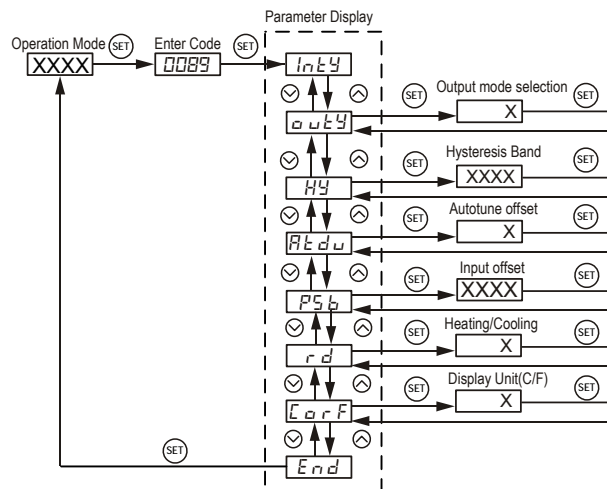

Figure 7. The system setup flow chart

**Note 9.** The value of outy determines the control mode: When it is set to, 2: PID control mode.

3: On/off control mode.

6: Limit control mode.

Setting value for 0, 1, 4, 5 should not be used for this controller.

The new outy setting will not take effect if the outy is changed until the controller is restarted .

**Note 10.** Hy is only used when controller is in on/off or limit control mode. It sets the hysteresis band for the controller.

**Note 11.** The auto-tune offset will shift the SV value down by the Atdu value during the auto tune process. It will prevent the system from damage due to overheating during auto-tuning.

**Note 12.** Rd is for system function selection, 1 for cooling, 0 for heating.

**Note 13.** Display unit selection CorF: 0 for Celsius (°C); 1 for Fahrenheit (°F).

### 6. Auto-Tune

The Auto-tune is a feature to let the controller automatically determine the PID constants to control the object efficiently. The auto-tune function will heat up the system then let it cool down. It will repeat this about three times. Based on the response time of the system, the built-in artificial intelligence program will calculate and set the PID parameters for the controller. The duration of auto-tune depends on how long to heat up and cool down the system. If the system is very slow to cool down, the auto tuning could take a long time.

#### 6.1. Auto-tune curve

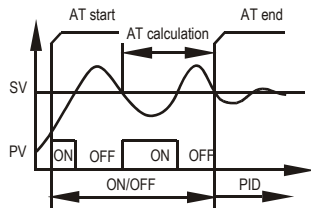

Figure 8. Auto tuning

#### 6.2. Auto-tune process

- 1) To active auto tuning: Press and hold > key until the "AT" indicator starts to blink, which indicates auto-tuning is in process. When "AT" stops blinking, the auto-tuning is finished. The parameter obtained from auto-tune will be remembered by the controller unless it is manually changed.
- 2) To stop auto-tuning: During auto-tuning process, press and hold > until "AT" indicator stops blinking. Then the previous PID parameters value are resumed.

### 7. On/off Control Mode

On/off control mode always work even if the system response is unknown. Instead of holding the temperature at a specific point as the PID mode, on/off control mode will hold the temperature in a narrow range. Instead of setting the P, I and D parameters, you just need to set the target temperature and the hysteresis band. It works similar to a mechanical thermostat. When the temperature passes the set point, the fan will be turned off. When the temperature drops back to below the hysteresis band (dead band) the fan will be on again.

To use the on/off mode, set Outy to 3. Then, set the Hy to the desired range based on control precision requirement. Smaller Hy results in tighter temperature control but also cause the on/off action more frequent. In the PID parameters menu (code 0036), only ot and FILT is used. P, I, D and SouF are not meaningful when controller is in on/off mode.

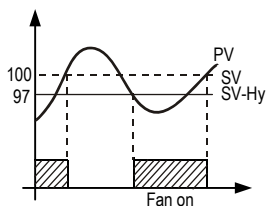

When heating, and outy=3,  
 If  $PV \leq (SV - Hy)$ , relay on  
 If  $PV \geq SV$ , relay off  
 (SV=100, Hy=3)

Figure 9. On/off control mode

### 8. Limit Control Mode

The limit control mode will shut the fan off when the (SV) is reached. The fan will not be turned on again until the controller is reset manually (press the SET for 5 seconds). When powered on, it will not start the fan until reset button pressed. The controller can't be reset when the temperature is within the hysteresis band (Hy).

To use the Limit control mode, set Outy=6. Then, set the Hy to the range that you want reset to be blocked. To start the fan, press SET key for 5 seconds or until the output indicator is on.

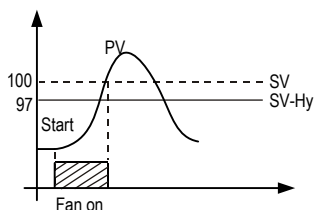

When heating, Outy=6  
 If  $PV \leq (SV - Hy)$ , relay on  
 If  $PV \geq SV$ , relay off  
 (SV=100, Hy=3)

Figure 10. Limit control mode

### Appendix 1

Table 4. Other types of thermocouple and their code that can also be used with this controller.

| Symbol | Description    | Working Temperature Range  |
|--------|----------------|----------------------------|
| T      | T Thermocouple | -200~400 °C; -320~752 °F   |
| r      | R Thermocouple | -50~1600 °C; -58~2900 °F   |
| J      | J Thermocouple | -200~1200 °C; -320~2200 °F |
| H r E  | Wre3/25 TC     | 0~2300 °C; 32~4200 °F      |
| b      | B Thermocouple | 350~1800 °C; 660~3300 °F   |
| S      | S Thermocouple | -50~1600 °C; -58~2900 °F   |
| Y      | K Thermocouple | -200~1300 °C; -320~2400 °F |
| E      | E Thermocouple | -200~900 °C; -320~1650 °F  |

