

Instruction Manual

TH220 TEMPERATURE AND HUMIDITY CONTROLLER INSTRUCTION MANUAL

Version 1.2 (Oct, 2017)

1. Overview

This plug-n-play temperature and humidity controller is designed for high relative humidity (>85%) and condensing environments, where slight temperature drop may cause condensation and could damage the sensor. This controller equipped with one of the most robust humidity sensors on the market. It can be fully recovered even immersed in water. Ideal for curing Fridge. The controller can control both temperature (heating or cooling) and humidity (humidifying or dehumidifying) at the same time.

2. Specification

Table 1. Specifications

Temperature Control Range	- 40 ~ 80 °C, - 40 ~ 176 °F
Temperature Resolution	0.1 °C (between -9.9 ~ 80 °C) 1 °C (between -40 ~ 10 °C) 0.1 °F (between -9.9~99.9 °F) 1 °F (between -40 ~ 10 °F, 100 ~176 °F)
Temperature Accuracy	0.5 °C
Temperature Control Mode	On/Off Control. Heating or Cooling
Temperature Control Output	15A, 120V or 240V AC *
Humidity Control Range	0~99.9% RH
Humidity Resolution	0.1% RH
Humidity Accuracy	4% RH
Humidity Control Mode	On/off control. Humidifying or dehumidifying
Humidity Control Output	15A, 120V or 240V AC *
Operating Temperature	0~50 °C
Dimension	91x140x46mm
Input Power	85 ~242VAC, 50Hz/60Hz
Sensor Cable Length	6 ft (2m)
Power Cable Length	3 ft (1m)

* Please note: Although both temperature and humidity output can handle up to 15A, the combined total power of the two channels are limited to 1500 Watts due to the limitation of input power cord.

3. Front Panel



Figure 1. Front Panel

Measured temperature window: In normal operating mode, this window shows measured temperature. In parameter setting mode, this window shows parameter name.

Measured humidity window: In normal operating mode, this window shows measured humidity. In parameter setting mode, this window shows parameter value.

Alarm indicator: When the alarm is muted, the alarm indicator (the small dot on the last digit) will be on.

SET key: Access the program settings and parameter settings.

UP key (Unmute): Increase the value. Press down momentarily to unmute the alarm.

DOWN key (Mute): Decrease the value. Press down momentarily to mute the alarm.

Temperature socket: Supply power to heater/cooler.

Temperature indicator: Red LED indicator; it is on when the temperature socket is energized.

Humidity socket: Supply power to the humidifier/dehumidifier.

Humidity indicator: Green LED indicator; it is on when the humidity socket is energized.

4. Setup Flow Chart

When the controller is powered on, it will display the measured temperature and humidity. The controller will keep running according to the saved setting. If the humidity or temperature sensor is shorted/disconnect, the controller will display "Err". Please see Figure 2 and 3 for the flow chart to set the parameters.

5. Parameter Settings

To change the target temperature or humidity, press SET key momentarily. The controller will show tSP (temperature set point), press SET again will show HSP (humidity set point). Use Up or Down key to change the tSP or HSP. See Figure 2 for details.

To change the other parameters, press SET key for 3 seconds, the RH window (bottom window) will show tE, Hu or SYS* (depending on which menu was set last time). tE menu is for temperature control settings; Hu menu is for humidity control settings and SYS* is for system settings. Press Down (or Up) key to change the RH window to Hu (or tE, SYS), which is the current selected menu, then press SET key to enter.

To change parameter settings, in the parameter setup mode, use Up or Down key to modify the parameter value. Then press SET key again to confirm the change. This instrument will automatically exit if no key is pressed for 10 seconds. Please see the Table 1 for the parameters.

* Menu SYS and parameter PSD are only applicable for TH220-W model.

Table 1. Parameters Description

Code	Description	Setting Range	Initial	Note
Menu for set point (Figure 2)				
tSP	tSP	Temp. Set Point	-40~176 °F -40~80 °C	1
HSP	HSP	Humidity Set Point	0~99.9 %RH	
Menu for parameters (Figure 3)				
Edt	Edt	Menu Selection	tE: Temp. Menu Hu: Humidity Menu SYS*: System Menu	TE 6
Temp. control settings (Edt = tE)				
C-F	C-F	Temp. Unit	C: Celsius F: Fahrenheit	F
tCM	tCM	Temp. Control Mode	Ht: Heating Control CL: Cooling Control	CL
TdF	TdF	Temp. Control Differential	0~50.0	3.0 1
toF	toF	Temp. Calibration Offset	-10.0~10.0	0 2
tAH	tAH	Temp. High Limit Alarm	-40~176 °F -40~80 °C	95.0 3
tAL	tAL	Temp. Low Limit Alarm	-40~176 °F -40~80 °C	
TAS	TAS	Temp. Anti-short Cycle Delay (only for cooling)	0~12 min	0 4
TSF	TSF	Temp. Sensor Failure Operation	ON: Output energized OFF: Output de-energized	OFF 5
Humidity control settings (Edt = Hu)				
HCM	HCM	Humidity Control Mode	deH: Dehumidifying H: Humidifying	H
HdF	HdF	Humidity Control Differential	0~50.0	3.0 1
HoF	HoF	Humidity Calibration Offset	-10.0~10.0	0 2
HAH	HAH	Humidity High Limit Alarm	0~99.9	90.0 3
HAL	HAL	Humidity Low Limit Alarm	0~99.9	
HAS	HAS	Humidity Anti-short Cycle Delay (only for dehumidifying)	0~12 min	0 4
HSF	HSF	Humidity Sensor Failure operation	ON: Output energized OFF: Output de-energized	OFF 5
System setting (Edt = SYS*)				
PSD	PSD	Device Access Password	100 ~ 999	666 7

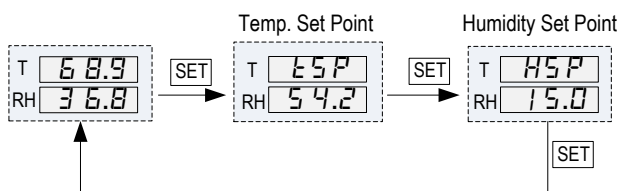

Figure 2. Flow Chart Part 1

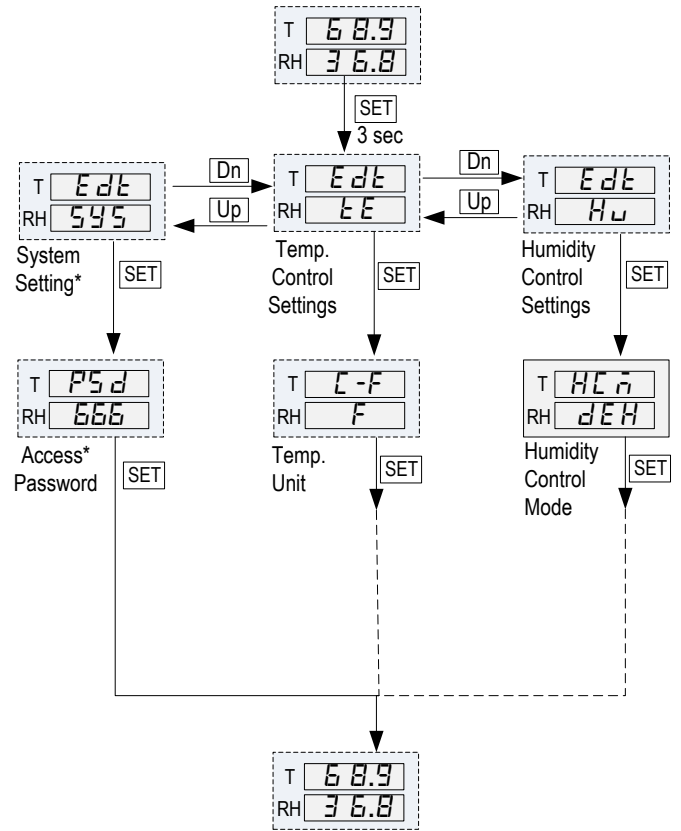

Figure 3. Flow Chart Part 2

Note 1. For heating (or humidifying), the output will be off when the temperature (or humidity) reaches the set point; it will be on again when the temperature (or humidity) drops down to tSP - tdF (or HSP - HdF).

For cooling (or dehumidifying), the output will be off when the temperature (or humidity) reaches the set point; it will be on again when the temperature (or humidity) rises to tSP + tdF (or HSP + HdF).

Small differential gives tight control. Large differential reduces the frequency of cycle on and off, and it will extend the life of relay and compressor.

Note 2. The offset is used to set an input offset to compensate the error produced by the sensor or input signal itself.

For example, for temperature reading, if the unit displays 37 °F when the actual temperature is 32 °F, setting parameter toF = - 5 will make the controller display 32 °F.

Note 3. The low limit alarm will be always lower than the high limit alarm. When the measured temperature (humidity) is higher than tAH (HAH), the temperature (humidity) high limit alarm will be on; when the measured temperature (humidity) is lower than tAL (HAL), the temperature (humidity) low limit alarm will be on.

When alarm is on, the display will be flashing between the measured value and alarm type. To mute the alarm when it is on, press the Down key momentarily. When the alarm is muted, the alarm indicator (see Figure 1, the small dot on the last digit) will be on. If the measured value gets out of the alarm zone then

gets back to the alarm zone again, the alarm will be on again. To resume the alarm, press the Up key, the alarm indicator will be off.

To disable the alarm, set High Limit Alarm = Low Limit Alarm.

Note 4. When The controller is used for cooling (or dehumidifying control) and load is a compressor, it should not turn on the compressor when it is at high pressure (just after turned off). Otherwise, it may shorten the life of compressor. The Anti-Short Cycle Delay function can be used to prevent the rapid cycling of the compressor. It establishes the minimum time that the output contact remains open (after reaching cutout) before closing again. The delay overrides any load demand and does not allow the output contact to close until the set time-delay value has elapsed. It gives time to release the refrigerant pressure through evaporator. It is typically set to 4-6 (minutes).

Note 5. The TSF (HSF) can be set to ON or OFF. When it is set to ON, the output will always be on when the sensor fails; when it is set to OFF, the output will always be off when the sensor fails.

For example, when the unit controls a refrigerator for food, you may want to set the TSF to ON if the sensor fails to keep the food cold. When it controls a heater, you may want to set the TSF to OFF for safety purpose.

Note 6. Menu selection parameter. tE menu is for temperature control settings; Hu menu is for humidity control settings and SYS is for system settings. SYS setting is only available to TH220-W model.

Note 7. Device access password (only available to TH220-W model). This parameter is used to lock the access to parameter settings on AuberSmart app. Please refer to figure 3.

6. How to install the sensor to the unit.

The connector of sensor contains a slot for fitting pin connection. It locates at the bottom of the controller. It also has a spring lock to prevent disconnections from accidental pulling on the cable.

To install the sensor to the controller: 1) Identify the key on the male sensor connector (Figure 4, a) and the notch on the female connector (Figure 4, b). 2) Hold the tail of the female connector, align the notch and the key, and push the female connector forward.

To remove the connector, hold the spring-loaded collar on the female connector and pull it back. Please see Figure 5.

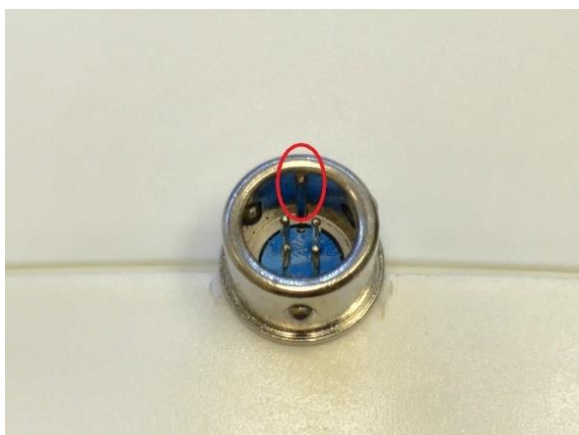

(a)

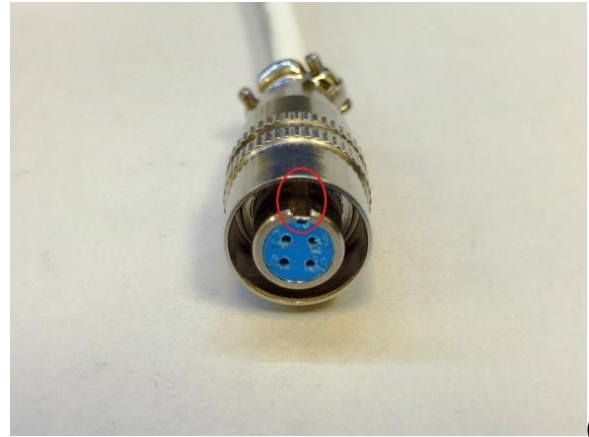

(b)



(c)

Figure 4. Install the sensor.



Figure 5. Remove the sensor.

Auber Instruments

5755 North Point Parkway, Suite 99
 Alpharetta, GA 30022, USA

www.auberins.com

E-mail: info@auberins.com Tel: 770-569-8420

Copyright 2007-2017, Auber Instruments All Rights Reserved.
 No part of this manual shall be copied, reproduced, or transmitted in any way without the prior, written consent of Auber Instruments. Auber Instruments retains the exclusive rights to all information included in this document.